

## Resonator

# Piezoelectric Resonator (8 to 16 MHz)

## FAR Family (C4 series G type)

### ■ DESCRIPTION

Fujitsu resonators C4 series (G type) feature originally developed single crystals with a high electromechanical coefficient (LiNbO<sub>3</sub> lithium niobate), the result is ultra compact packaging. C4 series (G type) with built-in capacitors for exclusive use in microcomputer clocks, and this series is chip type device for surface-mount.

### ■ FEATURES

- Ultra compact package.
- Wide frequency range in 8 to 16 MHz.
- C4 (G type), with built-in capacitors, is the best suited to the source of microcomputer clocks.
- C4 (G type) can be shipped in emboss-typed packages for automatic mounting.
- The resonators have superior shock and vibration resistance, preventing damage during automatic mounting process.

### ■ PACKAGE

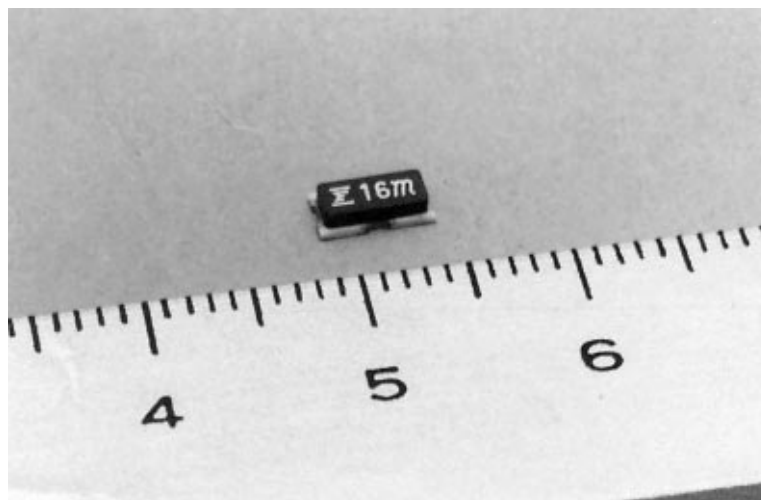

# FAR Family (C4 series G type)

## STANDARD CHARACTERISTICS

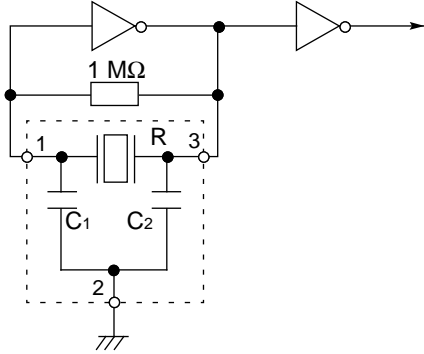
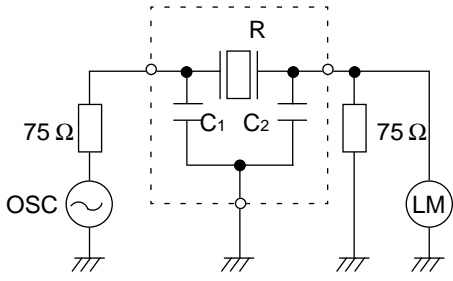
Series	C4 series (G type)	Remarks
Material	Lithium Niobate (LiNbO <sub>3</sub> )	
Frequency	8 to 16 MHz	
Standard frequency	See "Standard Frequency."	
Initial frequency deviation	±0.5% (μ)	
Temperature characteristics (-20°C to 60°C)	±0.5%	
Capacity of built-in capacitor	20±8 pF (Standard)	10±4 pF type are also available. However, the characteristics of 10±4 pF type should be specified by Fujitsu, considering matching data with applied IC (mainly microcomputer.)
Aging stability	Within ±0.1%	
Operating temperature	-30°C to +85°C	
Storage temperature	-40°C to +100°C	
Standard measuring circuit	<p>(1) Oscillation frequency</p>  <p>8 MHz to 10 MHz IC: 1/6 MB84069B x 2</p> <p>10 MHz to 16 MHz IC: 1/6 MC74HC04 x 2</p> <ul style="list-style-type: none"> <li>• V<sub>CC</sub>=5 V DC</li> <li>• R : Resonator</li> <li>• C<sub>1</sub>, C<sub>2</sub> : Loading capacitance (built-in)</li> </ul> <p>(2) Serial resonant resistance</p>  <p>Measuring equipment: Network analyzer R: Resonator</p>	

# FAR Family (C4 series G type)

## ■ STANDARD FREQUENCY

Standard frequency (KHz)	Package size	Resonant resistance
8,000 10,000	G	100 $\Omega$ max. (Symbol: 5)
11,000 11,059 12,000 16,000	G	75 $\Omega$ max. (Symbol: 2)

Note: • For oscillation frequency (in 8 to 16 MHz) other than standard, Fujitsu can also develop applicable part.  
 • Resonant resistance of the part is specified according to applied frequency as above.

## ■ NOTES ON USE

- Handle carefully
- Solder under the following conditions.  
5 seconds max. at 230°C (PCB)  
Do not apply extreme heat to the resonator. Recommended preheating is 150°C for one minute.
- Avoid extreme fluctuations in temperature during use.
- There is no specific direction in resonator mounting.
- Oscillation data should be examined when used in oscillation circuit with micon or other ICs.
- This is for reflow solder, not for flow solder.

# FAR Family (C4 series G type)

## ■ PART NUMBERING SYSTEM

FAR	-	C4		C		G	-	□□□□□	-	□	□	□	-	R
		(1)		(2)		(3)		(4)		(5)	(6)	(7)		(8) (9)

### (1) Series

Series	Single crystal	Capacitor
C4	LiNbO <sub>3</sub>	With built-in capacitors

### (2) Package Type

Specification	Type
C	Chip type

### (3) Package Size

Specification	Size
G	G type(Ultra compact)

### (4) Frequency (KHz)

See "■ Standard Frequency."  
[Example] 8.0 MHz 08000

### (5) Initial Frequency Deviation

Specification	Deviation
M	±0.5%

### (6) Built-in Capacitor

Specification	Capacitance
0	20±8 pF
1	10±4 pF

### (7) Resonant Resistance

Specification	Resonant resistance
2	75 Ω max.
5	100 Ω max.

# FAR Family (C4 series G type)

## (8) User-specific Special Symbols

Specification	Description
Name	No specification, no taping specification
—	No specification, with taping specification
A to Z	Serial number for custom design

## (9) Taping Specification

Specification	Description
R	12 mm width tape & reel

## ■ MARKING

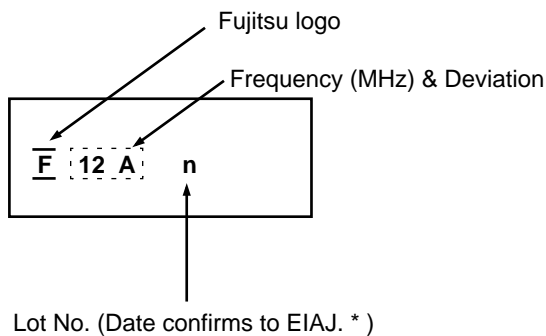

The stamp color varies according to built-in capacitor.

	Marking color
10 pF	Yellow
20 pF	White

### \*EIAJ RC1001 standard

Year	Jan	Feb	Mar	Apr	May	Jun	Jul	Aug	Sep	Oct	Nov	Dec
1993	A	B	C	D	E	F	G	H	J	K	L	M
1994	N	P	Q	R	S	T	U	V	W	X	Y	Z
1995	a	b	c	d	e	f	g	h	j	k	l	m
1996	n	p	q	r	s	t	u	v	w	x	y	z

**Note:** The code on and after Jan 1997 is specified repeatedly from "A".

# FAR Family (C4 series G type)

## PIN ASSIGNMENT

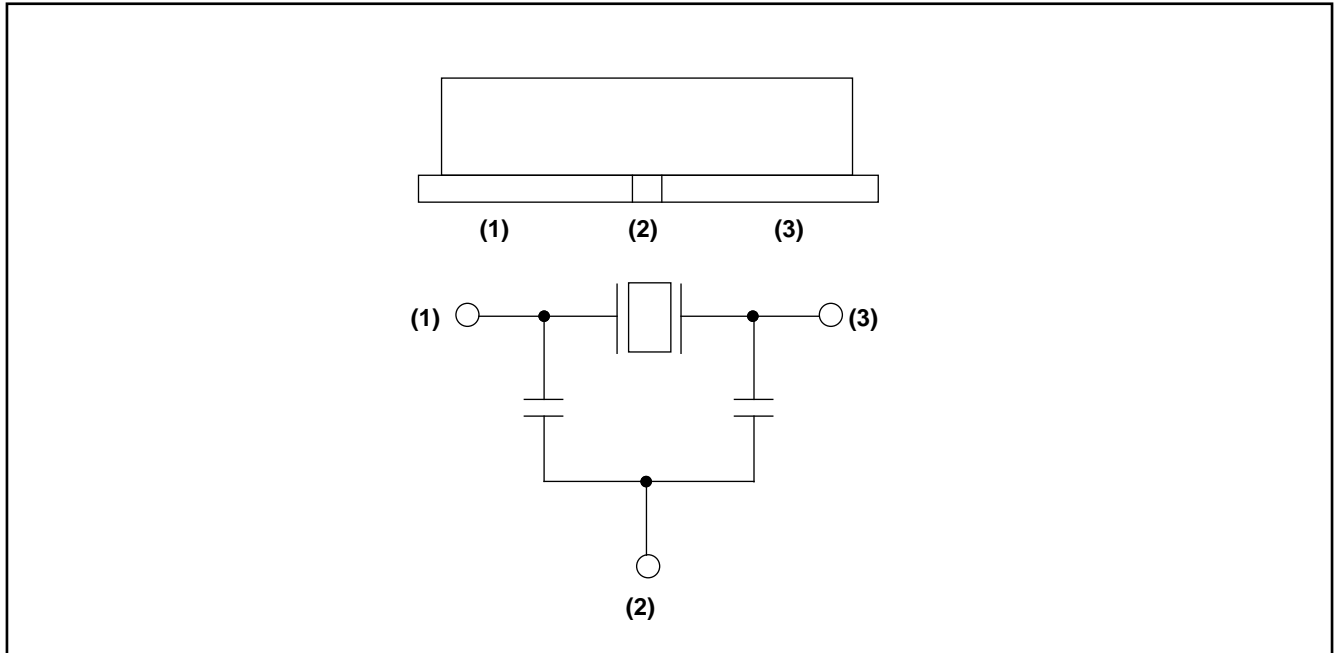

## DIMENSIONS

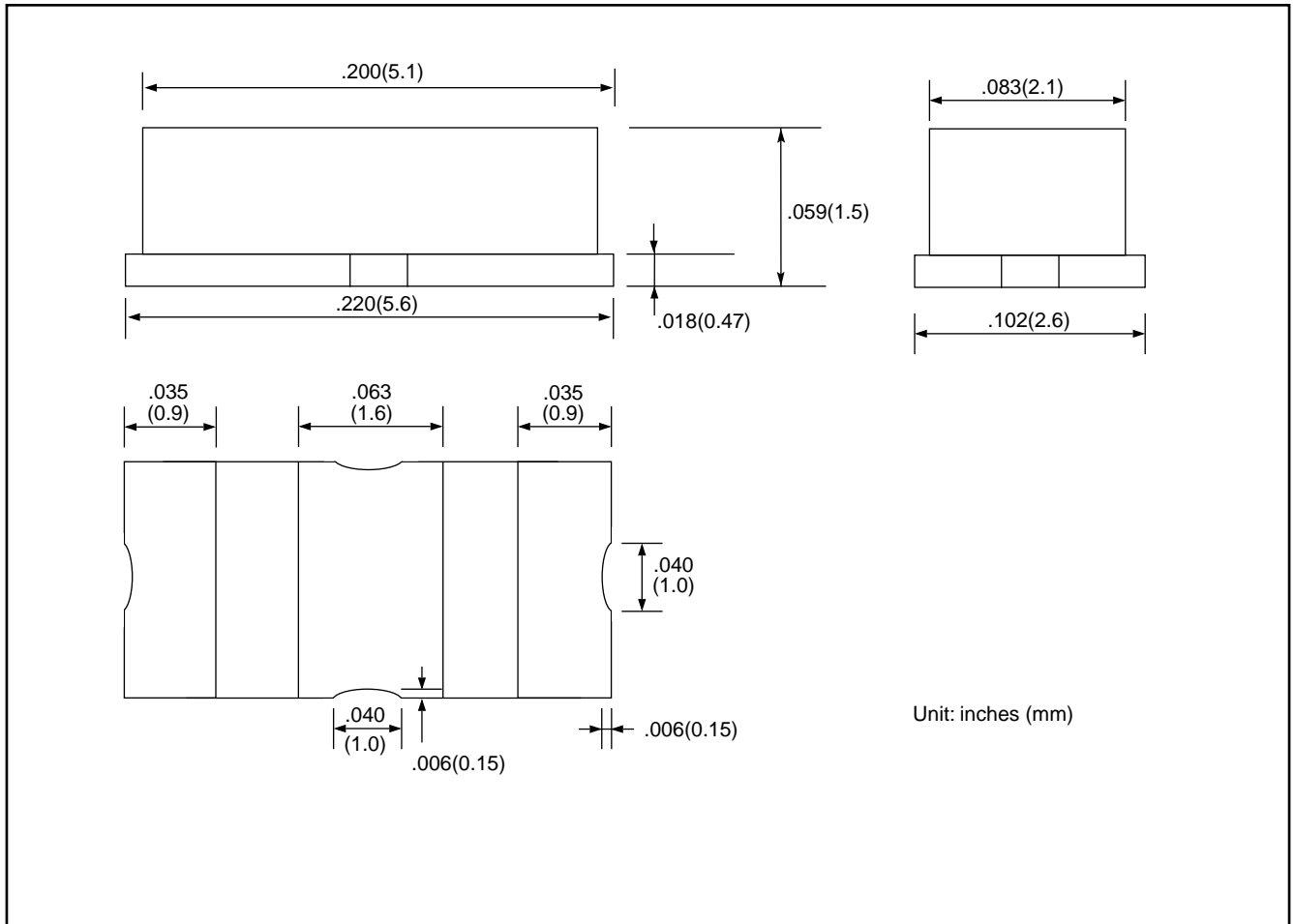

# FAR Family (C4 series G type)

## ■ TAPE & REEL DIMENSIONS

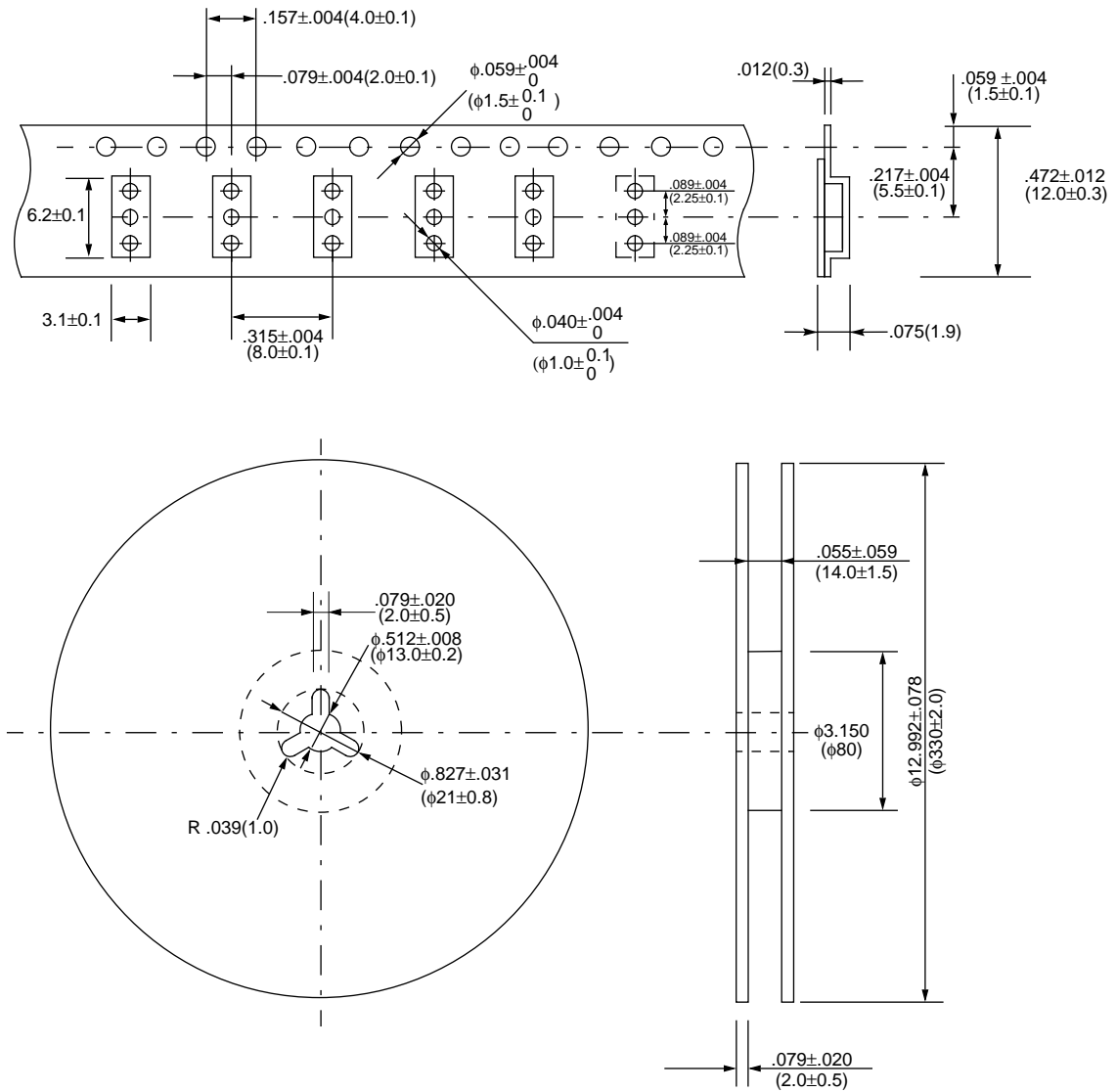

Unit: inches (mm)

### Reel quantity

QTY/reel	3,000 pcs
----------	-----------

# FAR Family (C4 series G type)

## ■ RESONATOR BUSINESS FLOW CHART

Oscillation frequency should be varied according to applied micro controller or another IC's.  
Fujitsu should recommend the resonator parts considering matching condition with applied IC.  
Following shows business flow chart.

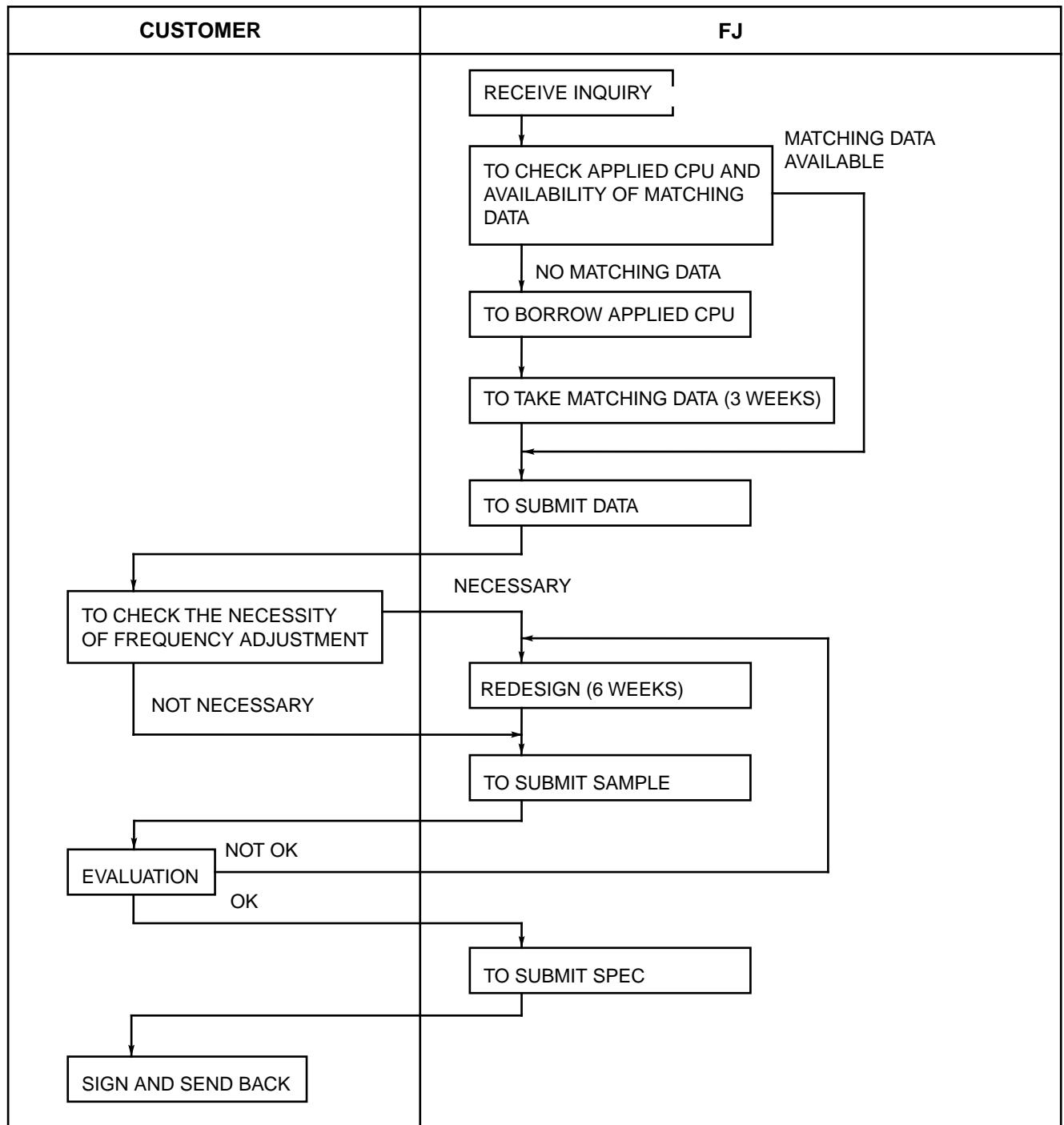



# FUJITSU LIMITED

*For further information please contact:*

## **Japan**

FUJITSU LIMITED  
Corporate Global Business Support Division  
Electronic Devices  
KAWASAKI PLANT, 4-1-1, Kamikodanaka  
Nakahara-ku, Kawasaki-shi  
Kanagawa 211-88, Japan  
Tel: (044) 754-3763  
Fax: (044) 754-3329

## **North and South America**

FUJITSU MICROELECTRONICS, INC.  
Semiconductor Division  
3545 North First Street  
San Jose, CA 95134-1804, U.S.A.  
Tel: (408) 922-9000  
Fax: (408) 432-9044/9045

## **Europe**

FUJITSU MIKROELEKTRONIK GmbH  
Am Siebenstein 6-10  
63303 Dreieich-Buchsschlag  
Germany  
Tel: (06103) 690-0  
Fax: (06103) 690-122

## **Asia Pacific**

FUJITSU MICROELECTRONICS ASIA PTE. LIMITED  
#05-08, 151 Lorong Chuan  
New Tech Park  
Singapore 556741  
Tel: (65) 281-0770  
Fax: (65) 281-0220

All Rights Reserved.

The contents of this document are subject to change without notice. Customers are advised to consult with FUJITSU sales representatives before ordering.

The information and circuit diagrams in this document presented as examples of semiconductor device applications, and are not intended to be incorporated in devices for actual use. Also, FUJITSU is unable to assume responsibility for infringement of any patent rights or other rights of third parties arising from the use of this information or circuit diagrams.

FUJITSU semiconductor devices are intended for use in standard applications (computers, office automation and other office equipment, industrial, communications, and measurement equipment, personal or household devices, etc.).

### **CAUTION:**

Customers considering the use of our products in special applications where failure or abnormal operation may directly affect human lives or cause physical injury or property damage, or where extremely high levels of reliability are demanded (such as aerospace systems, atomic energy controls, sea floor repeaters, vehicle operating controls, medical devices for life support, etc.) are requested to consult with FUJITSU sales representatives before such use. The company will not be responsible for damages arising from such use without prior approval.

Any semiconductor devices have inherently a certain rate of failure. You must protect against injury, damage or loss from such failures by incorporating safety design measures into your facility and equipment such as redundancy, fire protection, and prevention of over-current levels and other abnormal operating conditions.

If any products described in this document represent goods or technologies subject to certain restrictions on export under the Foreign Exchange and Foreign Trade Control Law of Japan, the prior authorization by Japanese government should be required for export of those products from Japan.